

OTHER HARDWARE

The recommended hardware for a typical 1204/1205 controller installation is shown in Figure 5.

Contactors should be mounted in a clean, dry location. If such a location is unavailable, a cover should be used to deflect dirt and water splash.

The precharge resistor connected to the main contactor, and the coil suppression diodes connected to the main contactor and to the forward/reverse contactors, are somewhat delicate components. Care should be taken to prevent damage to them during installation.

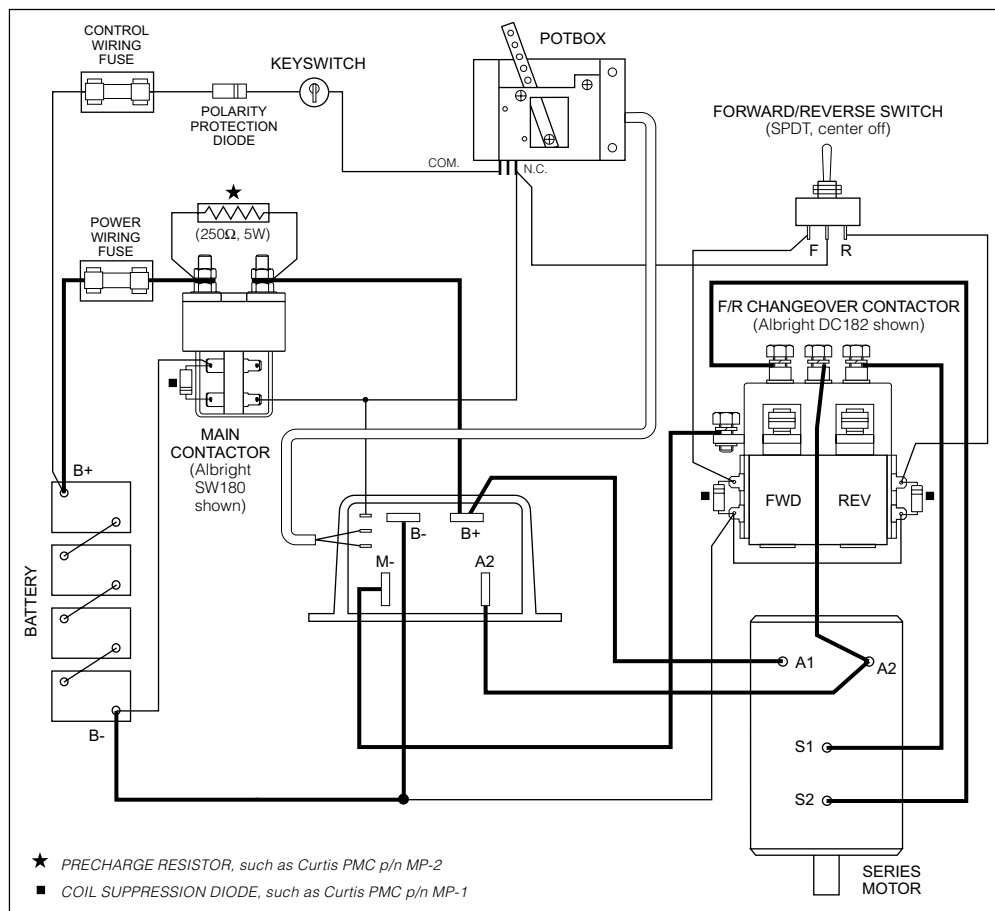

Fig. 5 Typical installation,
 Curtis PMC 1204/1205 controller.